

Carbide Punches with Machinable Steel Sleeve Type Head

These punches are recommended for medium to heavy punching requirements. They will out-perform steel punches many times, and they perform best when used in good quality dies.

The length of the steel sleeve (head thickness "T") is standard at 1/2", but may be ordered at any specified dimension.

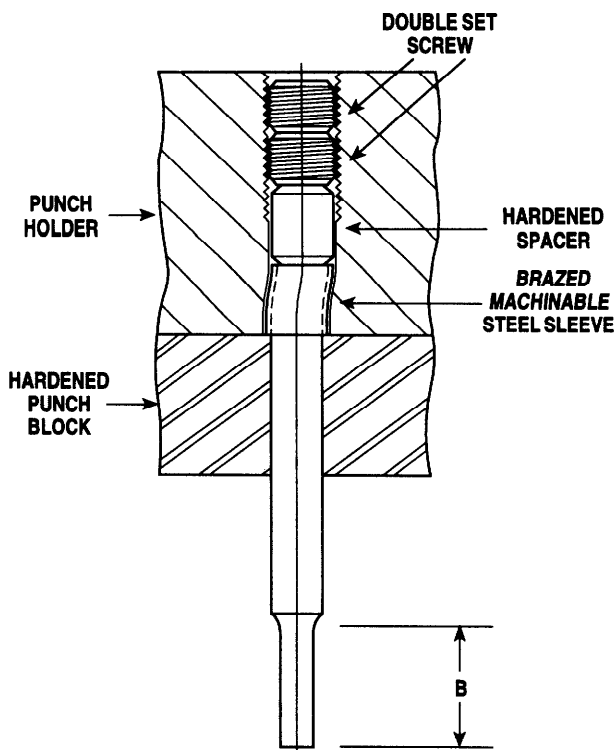

In the sectional view above, please note that:

1. Double set screws are recommended.
2. The hardened spacer next to the punch head is optional, and may be omitted.
3. By turning or grinding the shoulder of the soft steel head, the effective body length of the punch may be increased.
4. In most sizes, the length of the punch tip "B" may be renewed or increased by sending to OCP&D for regrinding, or by regrinding in your own shop.

Carbide Punches with Carbide Head and Hardened Steel Collar

These punches are for the stamper who prefers one piece carbide punches with carbide heads. They will out-perform steel punches many times when used in good quality dies.

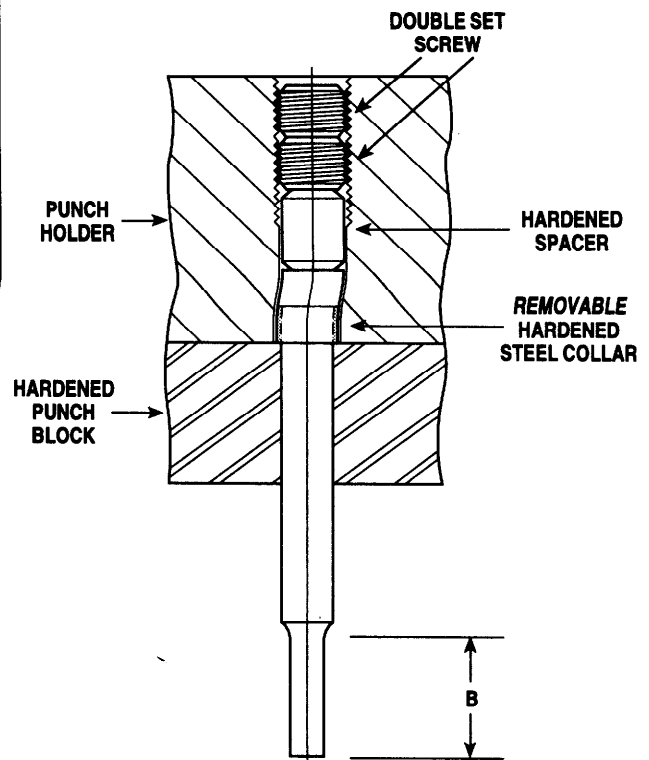

In the sectional view above, please note that:

1. Double set screws are recommended.
2. The hardened spacer is optional, and may be omitted.
3. To facilitate adjustment, each punch is supplied with a hardened steel collar which may be removed and ground off.
4. In most sizes, the length of the punch tip "B" may be renewed or increased by sending to OCP&D for regrinding, or by regrinding in your own shop.