



PIVOT PUNCH CORPORATION / SELECTIVE SERIES
HIGH SPEED LONG NOSE PILOTS

STEEL: M-2 R/C 60/62
HEADS DRAWN TO R/C 40-50

HLN()



Positive Pick Up Pilots

P Tolerance +.0002
 -.0000

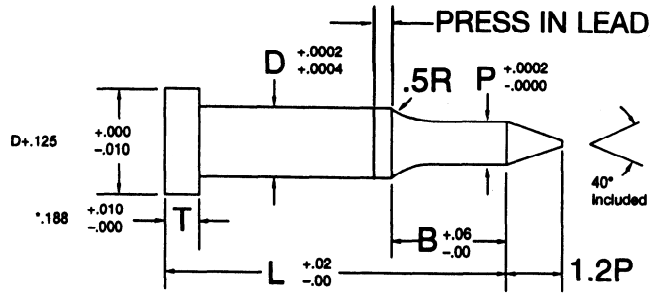

UNDER .188 SP PILOT NOSE IS 1.5P

P to D .0003 T.I.R.

When P = D Tolerance is +.0002
 +.0004

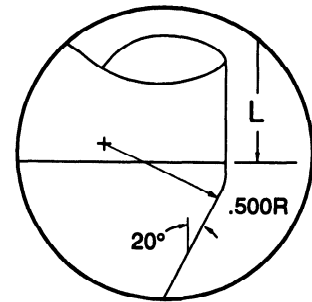

UNIVERSAL CODE: 110108 (SEE PAGE 175)

Shank		Point Length B	Round		Overall Length L M-2 Only													
D	Code		Min SP	Range P	2.50	2.75	3.00	3.25	3.50	3.75	4.00	4.25	4.50	4.75	5.00	5.25	5.50	
.3750	37	.75	.092	.186-.3750														
.4375	43		.092	.186-.4375														
.5000	50		.124	.224-.5000	2203	2303	3003	3103	3203	3303	4003	4103	4203	4303	5003	5103	5203	
.6250	62		.234	.309-.6250														
.7500	75		.299	.389-.7500														
1.000	100	.399	.484-1.000															
.3750	37	1.00	.092	.186-.3750														
.4375	43		.092	.186-.4375														
.5000	50		.124	.224-.5000	2210	2310	3010	3110	3210	3310	4010	4110	4210	4310	5010	5110	5210	
.6250	62		.234	.309-.6250														
.7500	75		.299	.389-.7500														
1.000	100	.399	.484-1.000															
.3750	37	1.25	.092	.186-.3750														
.4375	43		.092	.186-.4375														
.5000	50		.124	.224-.5000	2211	2311	3011	3111	3211	3311	4011	4111	4211	4311	5011	5111	5211	
.6250	62		.234	.309-.7500														
.7500	75		.299	.389-.7500														
1.000	100	.399	.484-1.000															

HOW TO ORDER HIGH SPEED LONG NOSE PILOT BODY DIA. CODE OVERALL LENGTH POINT LENGTH *P*
HLNC 50 32 10 X .375