

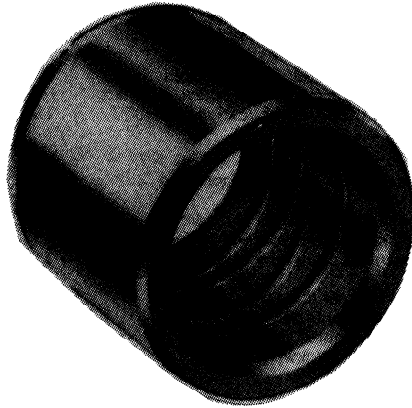

Lamina

Flange Type:

STRIPPER GUIDE PINS & BUSHINGS



BRONZE PLATED STRIPPER GUIDE PIN BUSHING

P NOM. PIN DIA.	B *	D	PART NO.
1	1 3/8	2 3/8	SG100L

*.015 stock left on this diameter for grinding to fit bored hole in die shoe.

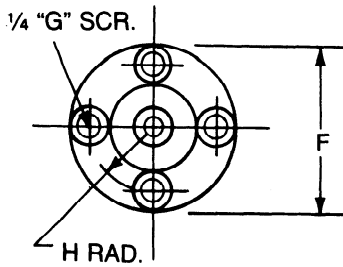
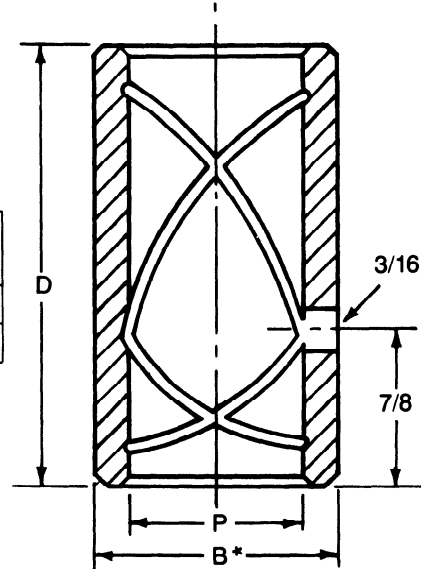

Lamina

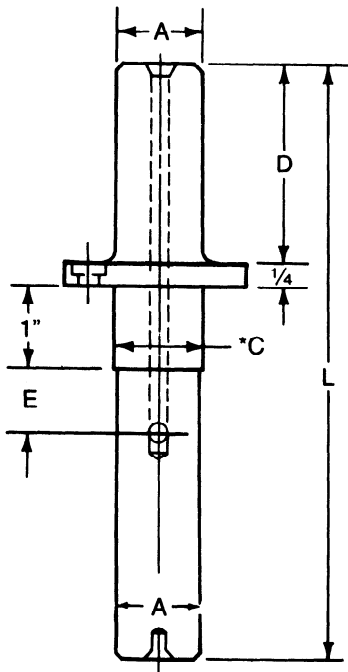
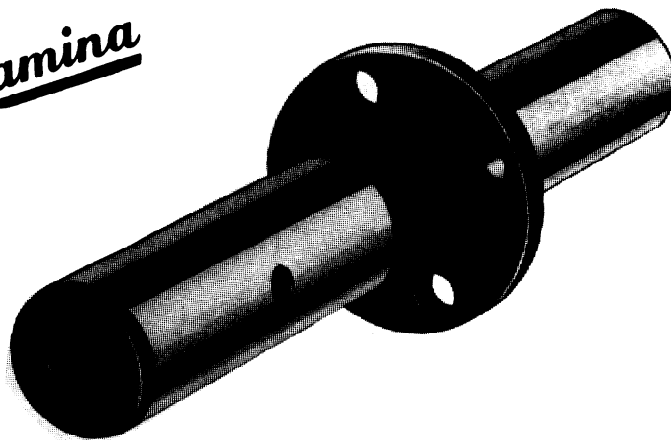

PLEASE ORDER BY PART NUMBER AND LENGTH.

STRIPPER GUIDE PIN								
A NOM. DIA.	D	E	F	G	H	PART NO.	L	C*
3/8	3 3/8	3	1 1/4	Flat Head	.719	F-8890	9	3/8
1	3 3/8	1 1/2	2	Soc. Head	.750	F-1080	8	1
1	3 3/8	1 1/2	2	Soc. Head	.750	F-1085	8 1/2	1
1	3 3/8	1 1/2	2	Soc. Head	.750	F-1090	9	1
1 1/4	3 3/8	1 1/2	2 1/4	Soc. Head	.875	F-1290	9	1 1/4

*Approximately .015 stock left on this diameter for grinding. Suggested finish bore size (for "C" Diam.) to be .005 over nominal pin diameter.