



VACUUM SLEEVES

VACUUM AWAY LOOSE SLUGS, SLIVERS
OR FINISHED PARTS IN FABRICATING DIES

THE PROBLEM OF LOOSE SCRAP — AND HOW TO CONTROL IT.

(A) THE PROBLEM: In metal fabricating, machine operators are often troubled with uncontrolled loose scrap or small finished parts. The following are your costly losses:

- (1) Production shut-downs.
- (2) Shearing of expensive punches and dies.
- (3) Damage to strip stock.
- (4) Rejection of finished parts.
- (5) Extra set-ups.

(B) THE CAUSES: Loose scrap or slugs in fabricating dies can be caused by the following factors:

- (1) Excessive clearance between punch and die opening.
- (2) Variations in stock thickness.
- (3) Variations in stock hardness.
- (4) Fabricating at high speeds.
- (5) Excessive Wear on punch and die.
- (6) Lubricants on stock strip cause slugs to stick to punch.
- (7) Magnetized punches.
- (8) Slugs hang to punch due to burrs.
- (9) Vibrations cause slugs to bounce out.

(C) THE SOLUTION: The VACUUM SLEEVE was designed and developed as an easy method to remove loose slugs or scrap. The VACUUM SLEEVE will convert compressed air into a vacuum which is applied at the die opening. This vacuum not only prevents slugs from pulling out with the punch, but it carries them away from the die surface through the vacuum source and deposits them in a container.

The advantage of the vacuum system over plain compressed air is — with vacuum you have control of the slugs or parts. With compressed air — pieces can fly back onto the working surface interfering with the die operation.

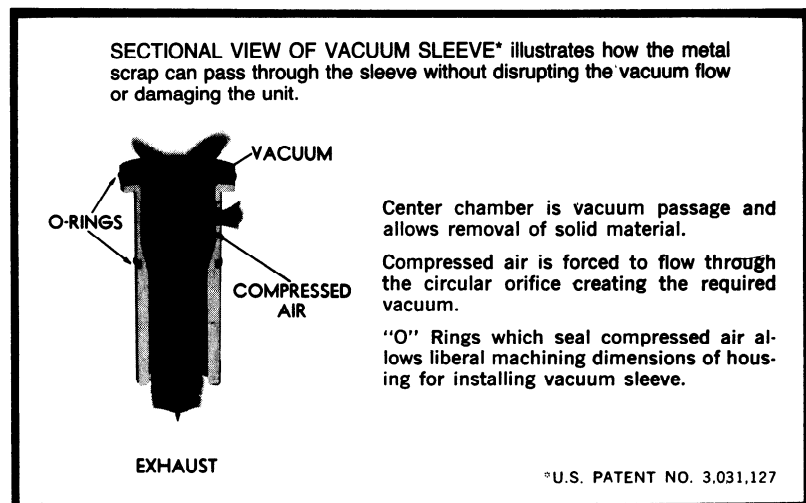
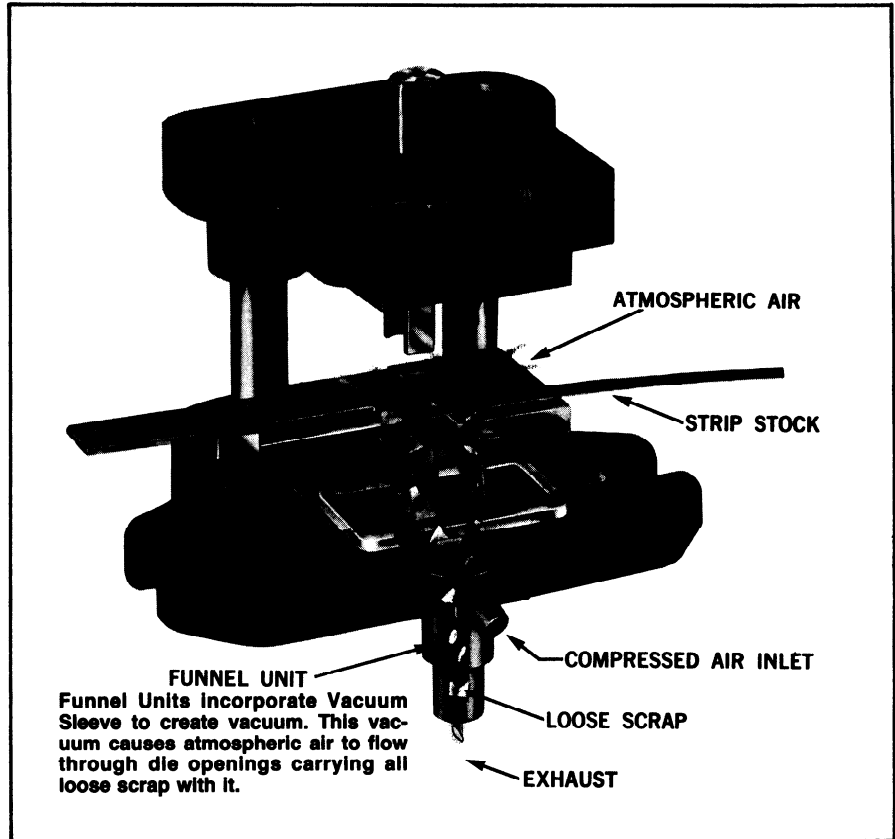

*U.S. PATENT NO. 3,031,127